

# Oil-free Compressed Air Technology



Ingersoll Rand (NYSE:IR) advances the quality of life by creating and sustaining safe, comfortable and efficient environments. Our people and our family of brands—including Club Car®, Ingersoll Rand®, Thermo King® and Trane®—work together to enhance the quality and comfort of air in homes and buildings; transport and protect food and perishables; secure homes and commercial properties; and increase industrial productivity and efficiency. We are a \$12 billion global business committed to a world of sustainable progress and enduring results.



# More than air, a history of innovation

**For more than 100 years,** Ingersoll Rand has inspired progress by driving innovation with revolutionary technology — creating new standards for how the world gets work done. We introduced our first oil-free compressor in 1912, and over the decades we've continued to develop rugged, reliable, industry-leading compressor technologies.

Ingersoll Rand is the technology leader in oil-free compressed air not only because we develop class-leading products, but also because we know our customers' industries, understand the demands placed on productivity and quality, and then offer highly engineered system solutions that make sense. No matter what your product, process, or location, Ingersoll Rand has the expertise, the oil-free technology, and the unmatched service to meet your needs.

**2003** Ingersoll Rand offers industry's first true variable-speed drive, oil-free compressor featuring HPM motor technology

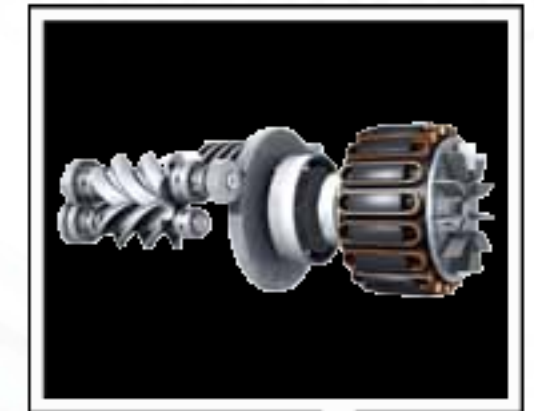

**1906** Ingersoll Rand becomes publicly traded company on NYSE



**1933** Technologically advanced oil-free reciprocating compressor goes to market

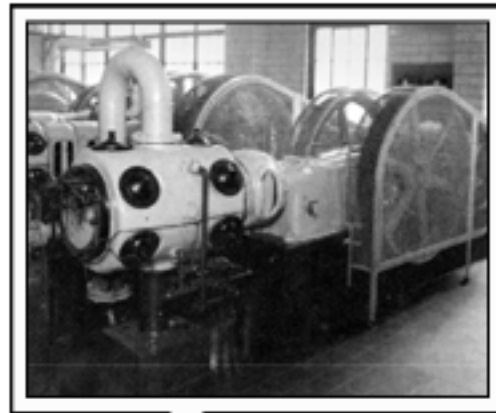

1910

1920

1930

1940

1950

1960

1970

1980

1990

2000

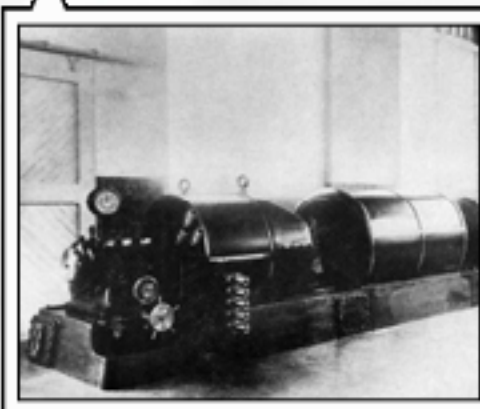

**1912** Ingersoll Rand pioneers oil-free centrifugal compressor technology

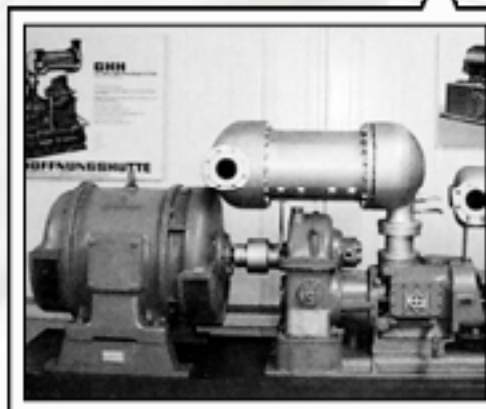

**1952** The world's first oil-free rotary compressor is introduced



**1968** First packaged centrifugal compressor is introduced (current model shown)



**1993** The 37 – 300 kW packaged rotary-screw compressor is introduced featuring Intellisys™, UltraCoat™ rotor protectant, and T15° F design

# When high air purity is a high priority



Oil-free



**Food and Beverage ▲**  
Oil-free compressors that deliver no oil into the air stream and minimize microbial content through high-temperature compression reduce contamination risk for food and beverage manufacturers.



**Pharmaceutical ▲**  
The highly regulated pharmaceutical industry requires 100% total quality built into manufacturing processes. Compressed air quality must be validated as part of GMP.



**Electronics ▲**  
High air quality is critical in this industry — you can't afford downtime or product spoilage with wet or oily compressed air.



**Chemical ▲**  
Whether manufacturing cleaning solutions, base stock pharmaceuticals, or anything in between, the compressed air quality must be of the highest purity to minimize risk of production interruption or higher cost liability.



**Textile ▲**  
High-tech air jet looms require super-clean, dry, 100% oil-free compressed air, which is why Ingersoll Rand has been a critical supplier to this industry for many years.



**Utilities ▲**  
Compressed air quality is too important to risk, so when specifying instrument air for utilities, most engineers request oil-free compressors.

There's a lot riding on the quality of your air. The presence of particles, condensation, oil, and oil vapor in a compressed air system can lead to downtime, product spoilage and recall, damage to your brand reputation, or worse, harmed consumers and product liability.

No matter what industry or critical application, you can count on Ingersoll Rand to offer solutions that mitigate risk and ensure delivery of the highest air purity possible.

# Oil-free, risk-free

**How pure is your air?** One of the keys to ensuring you achieve and maintain acceptable air quality for your critical application is to know industry air quality standards and their allowable levels of contaminants. The lower the particular class rating, the purer the air should be.

### ISO 8573-1:2010 Air Quality Classes

ISO 8573-1:2010 CLASS	Solid Particulate			Mass Concentration mg/m <sup>3</sup>	Water		Oil Total Oil Aerosol liquid and vapour mg/m <sup>3</sup>
	0.1-0.5 micron	0.5-1 micron	1-5 micron		Vapour Pressure Dew point	Liquid g/m <sup>3</sup>	
0	As specified by the equipment user or supplier and more stringent than Class 1						
1	≤20,000	≤400	≤10	-	≤-70°C	-	0.01
2	≤400,000	≤6,000	≤100	-	≤-40°C	-	0.1
3	-	≤90,000	≤1,000	-	≤-20°C	-	1
4	-	-	≤10,000	-	≤+3°C	-	5
5	-	-	≤100,000	-	≤+7°C	-	-
6	-	-	-	≤5	≤+10°C	-	-

ISO 8573-1:2010 Class 0 specifies air quality standards for critical manufacturing processes within the food and beverage, pharmaceutical, textile, and electronics industries. It is the most stringent class, covering oil contamination in aerosol, vapor, and liquid forms.

Some compressor manufacturers have marketed their units as being *essentially* oil-free, but this isn't necessarily the case. If you need *guaranteed* pure air for your critical application, then you need Ingersoll Rand.



# Oil-free compressors in a class by themselves

With an Ingersoll Rand oil-free compressor, you don't have to worry about contaminated air, regardless of the technology you choose.

Our oil-free rotary-screw and centrifugal compressors were rigorously tested by TÜV Rheinland\* — a global leader in independent testing and assessment services — and earned ISO 8573-1:2010 Class 0 certification.



Only Ingersoll Rand delivers ISO Class 0 in both rotary-screw and centrifugal technologies. Whether you're in food and beverage, pharmaceuticals, electronics, or any other critical application, count on Ingersoll Rand oil-free technology to deliver pure air and peace of mind.

# Two-stage, oil-free rotary-screw air compressors

**The reliable workhorse.** Since its introduction in 1993, the Ingersoll Rand oil-free rotary-screw compressor has earned a reputation for being a highly reliable supplier of pure air. Its rugged design sets the standard for efficiency and durability. With an Ingersoll Rand oil-free rotary-screw compressor in your operation, you benefit from knowing you can run 24 / 7 with virtually no downtime.



## Superior technology

Our time-proven two-stage compression module features precision-machined rotors and gearing, advanced UltraCoat rotor protection, anti-friction bearings, stainless-steel air seals, and a unique labyrinth oil seal design — all ensuring years of reliable, trouble-free operation.



## Oil-free heritage

Over the years, Ingersoll Rand has delivered more than 100,000 sets of oil-free rotors to industries that rely on high-purity products such as pharmaceuticals, food and beverages, and electronics.

## Stainless-steel rotors

Ingersoll Rand pioneered the use of stainless-steel rotors in the demanding second stage to guarantee longer air end life, and to safeguard the quality of your compressed air.

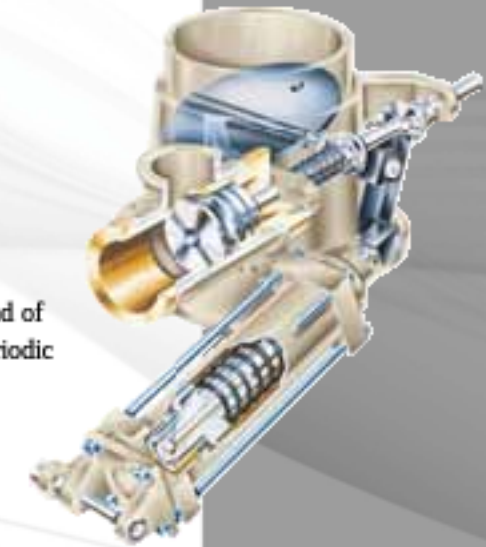

## Inlet valve superiority

Ingersoll Rand uses hydraulic valve actuation instead of pneumatic controls. This eliminates the need for periodic diaphragm replacement, preventing unnecessary downtime and maintenance costs.

## Dual-vented seals

Our stainless-steel ring seals and labyrinth oil seals provide dual-vented, 100% guaranteed oil-free air.

# UltraCoat™ — energy savings and longer life

Compressor rotors take a beating. Over time their surfaces can deteriorate, making rotors increasingly susceptible to compressed air impurities and temperature fluctuation, which lead to reduced efficiency, decreased air purity, and compressor failure.

Ingersoll Rand eliminates this problem with UltraCoat, an advanced rotor and housing protection process that ensures the most durable coating, with unmatched adhesion and temperature resistance.

Every Ingersoll Rand oil-free rotor and housing is specially prepared, creating a surface texture to which the UltraCoat micro-coating bonds with the tightest, longest-lasting grip possible.

We also use stainless-steel and aluminum piping to link the compressor's intercooler with the stainless-steel second stage rotors. This way, condensation during the cooling process won't cause corrosion or rust, further extending the life of the UltraCoat coating and rotors.

Ultimately, UltraCoat delivers greater reliability in performance and air quality, rotor longevity, increased uptime, and reduced energy costs.

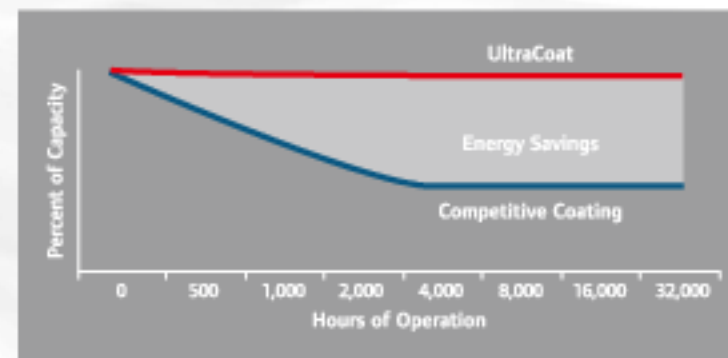

# A smart choice for reliable, repeatable processes

## 60 Hz (50 – 400 hp)

Nominal hp	Model L FAD at 100 psi(g) cfm	Model H FAD at 125 psi(g) cfm	Model HH FAD at 150 psi(g) cfm	Width in	Length in	Height in	Weight lb
50	214	179	—	54	88.5	75.4	5111
60	266	229	—	54	88.5	75.4	5364
75	333	288	268*	54	88.5	75.4	5364
100	419	407	378*	54	88.5	75.4	5500
125	585	523	477	62.5	106	93.3 / 72.5**	6,437 / 6,709**
150	690	690	565	62.5	106	93.3 / 72.5**	6,452 / 6,724**
200	911	854	759	62.5	106	93.3 / 72.5**	7,099 / 7,385**

## 50 Hz (37 – 300 kW)

Nominal kW	Model SL FAD (m <sup>3</sup> /min) at 7.0 bar(g)	Model SM FAD (m <sup>3</sup> /min) at 8.5 bar(g)	Model SH FAD (m <sup>3</sup> /min) at 10.0 bar(g)	Width mm	Length mm	Height mm	Weight kg
37	6	5.1	—	1372	2248	1917	2387/2410**
45	7.6	6.5	—	1372	2248	1917	2497/2520**
55	9.6	8.6	7.7*	1372	2248	1917	2577/2600**
75	12.5	11.6	10.7*	1372	2248	1917	2862/2705**
90	15.9	13.6	13	1588	2692	2374/1841**	3270/3425**
110	19.4	18	15.3	1588	2692	2374/1841**	3350/3505**
132	22.8	21.4	18.8	1588	2692	2374/1841**	3400/3555**
150	25.9	24.6	22.1	1588	2692	2374/1841**	3450/3605**
200	35	32.6	27.4	1930	3048	2438/2065**	5222/4830**
250	45.2	41.5	35.5	1930	3048	2438/2065**	5262/4870**
300	—	46.70	43.3	1930	3048	2438/2065**	5512/5120**

FAD (Free Air Delivery) cfm and m<sup>3</sup>/min are full-package performance ratings in accordance with CAGI / Pneurop acceptance test standard PN2CPTC2 or ISO 1217.

\*Available in water-cooled configuration only.

\*\*Specification given with air-cooled value first, then water-cooled.

# Unleashing the full potential of variable-speed technology

Nirvana

**If you have a critical oil-free application** requiring the lowest operating cost, you can't afford to take chances with a compressor system that delivers anything but the absolute highest quality air, reliability, and efficiency. Not a problem with an Ingersoll Rand Nirvana — the world's first true variable-speed drive (VSD) oil-free compressor system.



## Purely better

While other VSD compressors also deliver stable pressure, soft-starting, and improved part-load efficiency over fixed-speed compressors, only Nirvana enables you to reach the full potential of variable-speed technology. With a Nirvana system, you get ultra-reliability and efficiency, virtually maintenance-free operation, unlimited starts and stops, and peace of mind knowing your air is 100% pure.

## Real savings, real satisfaction

Energy costs can be as much as 60% of the lifecycle cost of an air compressor. The Nirvana system helps you reach the full potential of variable speed through the absolute lowest energy cost and the highest efficiency possible.

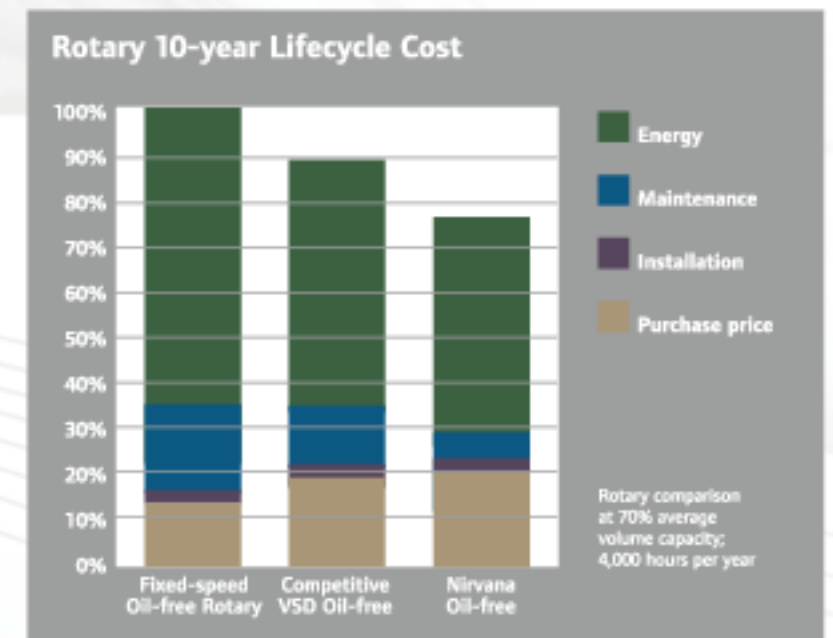
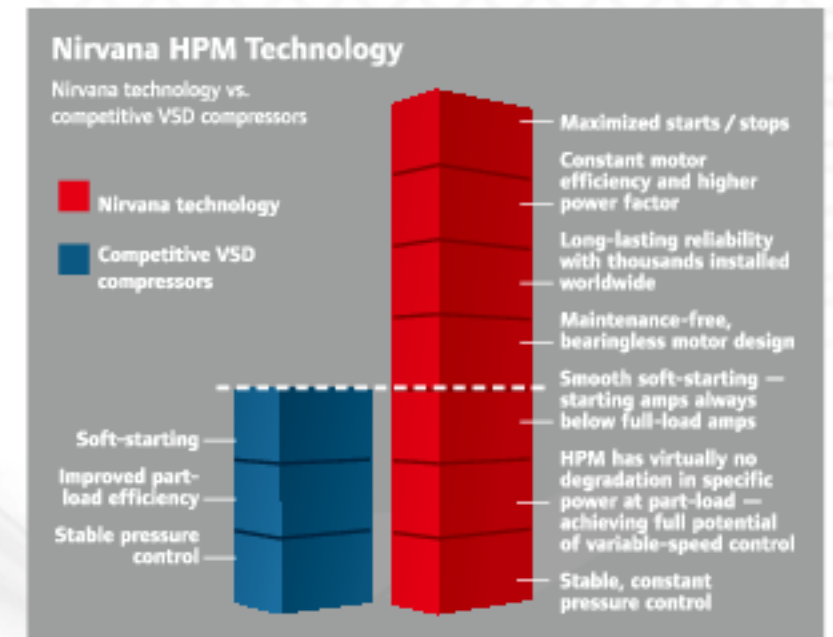

# The Nirvana advantage

## Achieve a higher plane of performance

There's never been a compressor system as advanced as Nirvana. It's synergy in motion — a combination of transcendent, inter-dependent technologies including the revolutionary Hybrid Permanent Magnet (HPM) motor, and more than a century of proven engineering expertise and innovation.

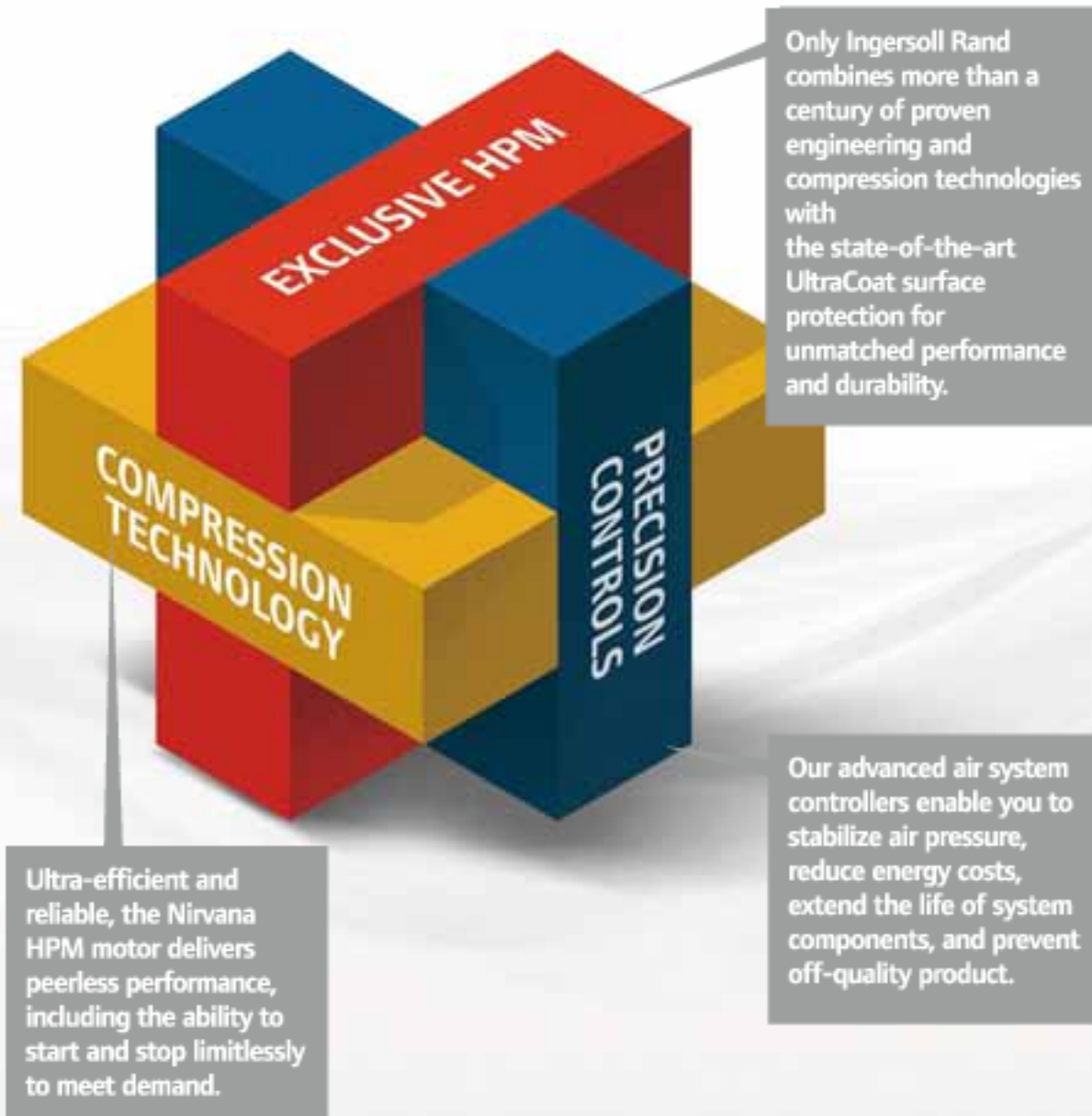

A revolutionary motor coupled with advanced controls and proven compressor technologies

### Limitless starts and stops

Nirvana is designed to start and stop limitlessly to meet your compressed air demands while never going above full-load amps. HPM motor technology also has unmatched efficiency throughout the turn-down range, providing savings no matter what your demand profile requires.



### No wasted energy

The Nirvana HPM motor requires less power at start-up, never operates at more than full-load amps, and shuts down immediately at minimum speed to avoid wasted energy. Nirvana ensures constant pressure throughout the entire operating range. At start-up, induction motors require a power surge of up to twice full-load current in order to overcome initial inertia. They also run unloaded when demand is below minimum, reducing efficiency and driving up energy costs.

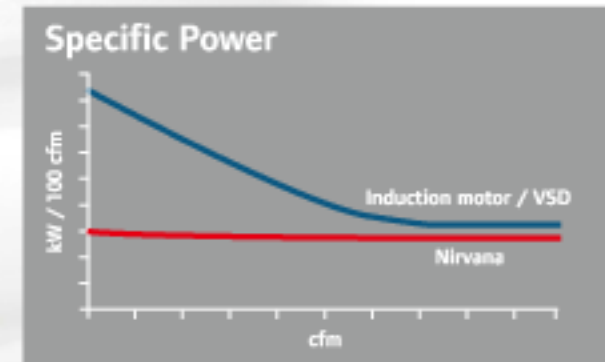

### Proven airends

Our rotary-screw airends deliver full potential through unparalleled rotor profile accuracy and repeatability. Stainless-steel rotors are used in the demanding second stage for maximum corrosion resistance. UltraCoat surface coating is also applied to the rotors and all housing surfaces for unmatched durability and performance.

### Precision-wound

With its precision-wound design, the Nirvana HPM motor eliminates inefficiencies and hot spots common to conventional, random-wound induction motors. These hot spots can cause insulation and motor failure.

### Simpler and more reliable

The Nirvana HPM motor has fewer moving parts, and flanges directly onto the compressor drive shaft, making the motor more reliable and 100% maintenance-free. Its bearing-free design eliminates the need for greasing or replacing motor bearings. The HPM motor is also designed to operate continuously in temperatures up to 115° F (46° C).

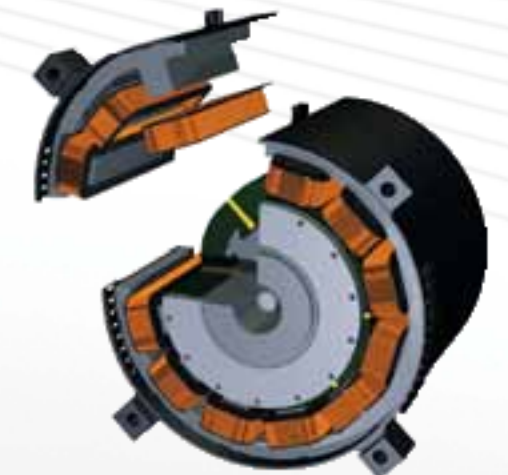



# Perfect solutions for critical operations

60 Hz									
Model (HPM Style)	FAD at 100 psig cfm	FAD at 125 psig cfm	FAD at 150 psig cfm	Discharge Air NPT in	Nominal hp	Width in	Length in	Height in	Weight lb
IRN50H-OF	200	180	159	1.5	50	43.9	81.9	79.7	3482
IRN60H-OF	237	220	198	1.5	60	43.9	81.9	79.7	3482
IRN75H-OF	331	299	269	1.5	75	52	81.8	76.7	4500
IRN100H-OF	435	400	368	1.5	100	52	81.8	76.7	4500
IRN125H-OF	563	504	444	2	125	74.2	100.3	95.9	7088
IRN150H-OF	676	616	555	2	150	74.2	100.3	95.9	7088
IRN200H-OF	881	816	751	2	200	74.2	100.3	95.9	7088

50 Hz									
Model (HPM Style)	FAD (m <sup>3</sup> /min) at 7 bar(g)	FAD (m <sup>3</sup> /min) at 8.6 bar(g)	FAD (m <sup>3</sup> /min) at 10.3 bar(g)	Discharge Air BSPT in	Nominal kW	Width mm	Length mm	Height mm	Weight kg
IRN37K-OF	5.66	5.07	4.50	1.5	37	1115	2080	2024	1579/1624**
IRN45K-OF	6.71	6.20	5.61	1.5	45	1115	2080	2024	1579/1624**
IRN55K-OF	9.37	8.47	7.62	1.5	55	1321	2078	1948	2041
IRN75K-OF	12.32	11.33	10.42	1.5	75	1321	2078	1948	2041
IRN90K-OF	15.4	13.7	12.1	2	90	1885	2547	2435	3215
IRN110K-OF	18.8	17.1	15.4	2	110	1885	2547	2435	3215
IRN132K-OF	22.3	20.4	18.6	2	132	1885	2547	2435	3215
IRN160K-OF	25.6	24.4	22.8	2	160	1885	2547	2435	3215

# Advanced controls

If you have a multiple-compressor installation, then you probably know that maintaining optimum average pressure along the entire line can be challenging, inefficient, and costly. Load / unload pressures are commonly offset to keep the compressors from starting at the same time, but doing so limits the system's ability to meet demand, and basic control settings can drift over time. This causes wide pressure swings that result in off-quality product, wasted energy, and shortened compressor life.

Ingersoll Rand advanced controllers — when coupled with our extensive system audit services — enable you to optimize air efficiency, deliver consistent flow and pressure, and extend the life of system components. Ultimately, you'll stabilize your pressure and reduce energy costs.

## Intelliflow™ Air System Pressure Controller

Intelliflow provides precise air pressure control of production processes by separating supply-side air from demand-side air. As a result, supply-side air is not affected by incidents on the demand side. Intelliflow can lower demand pressure precisely — saving lost energy costs and better ensuring consistent product quality.



## Intellisys Energy Optimizer

When incorporated into a Nirvana VSD-enhanced, fixed-speed compressed air system, the IEO provides the utmost in energy savings. The controller designates the Nirvana as a "trimming" or "lead" compressor. If only one compressor is needed to satisfy demand, the more efficient Nirvana will run. When demand exceeds the capacity of the Nirvana, one or more of the fixed-speed compressors will start at full capacity and the Nirvana trims back in output to precisely and efficiently satisfy demand in excess of the fixed-speed capacity. As demand drops, the IEO turns off the fixed-speed units, leaving the Nirvana to run by itself again.

### Enhance reliability

Control up to eight rotary-screw or reciprocating compressors from any manufacturer, and continuously monitor air system quality.

### Save energy

Overcome the problems associated with compressor trains and reduce the control pressure band.

### Increase productivity

Automate compressor control and optimize compressor scheduling to meet varying plant demand.

# As Ace As Aeolus

Ingersoll Rand AS Series Oil-free Scroll Air Compressor  
Lead to revolution for air compressor



## Major Advantages

- Smaller footprint, save more space in compressor room
- Fewer components, higher reliability
- Lower sound level, healthy work environment
- Perfectly applicable to all industries
- Less consumables, longer service life
- No metal friction, less maintenance
- Oil-free compression, no pollution
- Zero emission, green and environmental-friendly

## Excellent Compression Model

- Aluminum shell, light weight
- Built-in centrifugal fan on the air-end ensures sufficient cooling air
- Efficient cooling module control air-end temperature effectively
- 5.5kW Dual-inlet design of air-end makes the compression more stable and efficient



## Efficient Cooling Fan



- Small size, large airflow
- 24V DC power, safe and stable
- Aluminum material, light but durable
- Well known brand for quality assurance

## Fin-tube Heat Exchanger



- Fin-tube design
- Anti-corrosion copper tube
- Efficient cooling fin module

## Intelligent Controller

- Large size with interactive display
- Large navigation button and intuitive navigation control.
- LCD screen with friendly and visual display
- Chinese/English language display
- Fault protection, air-end fault alarm for safe operation of machine
- 3 control modes: local, remote, communication
- Standard RS-485 interface for remote start/stop, detection of working status
- Multi-level control and operation logics
- Multiple air-end backup operation



## Parameters and Specifications

Ingersoll Rand AS Series Oil-free Scroll Air Compressor (50 HZ)							
Model	Max Working Pressure barg	Nominal Power kW	Air Flow m <sup>3</sup> /min	Connection Size BSPT	Dimension (LxWxH) mm	Weight kg	Sound Level dB(A)
AGM2	8	2.2	0.24	1/2"	830 × 740 × 910	204	58
ASH2	10	2.2	0.21	1/2"	830 × 740 × 910	204	58
AGM4	8	3.7	0.40	1/2"	830 × 740 × 910	231	58
AGM5	8	5.5	0.60	1/2"	830 × 740 × 910	240	59
ASH5	10	5.5	0.53	1/2"	830 × 740 × 910	240	59
AGM7	8	7.7	0.84	1"	1445 × 800 × 1000	438	62
ASH7	10	7.7	0.74	1"	1445 × 800 × 1000	438	62
AGM11	8	11	1.20	1"	1445 × 800 × 1000	495	64
ASH11	10	11	1.06	1"	1445 × 800 × 1000	495	64

\* FAD (Free Air Delivery) is ratings of full package performance in accordance with ISO 1217 Annex C.

\*\* Sound level at the work station (±3 dB(A)), determined according to noise test code ISO 1151 and noise measurement taken at the duct of inlet and outlet of the standard compressor.

# Ingersoll Rand

Reciprocating Single- and Two-stage Air Compressors  
2-25 hp

*Innovation*

*Reliability*

*Efficiency*



**IR** Ingersoll Rand  
Industrial Technologies

# Legendary Performance

**For more than a century**, Ingersoll Rand has inspired progress by driving innovation through revolutionary technology and talented people.

It's a legacy of creating new standards for how the world gets work done. We're the technology leader in compressed air not only because we develop best-in-class products, but also because we stand behind our customers in all aspects of what we do. No matter what your product, process or location, Ingersoll Rand has the expertise, the technology and the unmatched service to meet your needs.



**INGERSOLL-RAND**

## T-30 Legendary Performance > > >

**1929**

Initial production model of Type-30 design with vertical cooling fins; combination of concave and convex tank heads.



**1950s**

Updraft air cleaner added.



**1970s**

First units from Campbellville, KY plant establish a new reputation for workmanship and service.



**1872**

Ingersoll Rand tradition begins with its first reciprocating air compressor.



**1940s**

Design enhanced with large U-frame motor and improved piping.



**1960s**

Modern Type-30 design emerges with horizontal cooling fans, smaller T-frame motor, convex tank heads, fully-welded construction and drive-belt guard.



## Providing Customer-driven Compressor Solutions

When you've been delivering reliable reciprocating compressor results for more than 100 years, it's natural that your corporate culture supports a strong tradition of evolutionary enhancements. Every new generation of employees builds on the experience and insights of their mentors. Today's legendary Ingersoll Rand air compressors started with an original rock-solid design and have steadily improved with added control and performance upgrades over the years.

They are world-renowned for their impressive legacy of long-life performance, ease of service and evolutionary design enhancements.

### Efficient. Reliable. Built to last.

Ingersoll Rand has sold millions of reciprocating compressors worldwide.

Ingersoll Rand



1990s

Fully packaged units with E-series starters and CSA package certification are introduced.



2002

Compact single-stage compressors introduced.



2006

Fully packaged model with aftercooler, automatic tank drain, and low-oil-level shutdown is top choice for round-the-clock applications.



1980s

First blue-colored units feature new enhancements.



2000

Premier Series packaging adds dual control, deluxe starter, and liquid-filled pressure gauge.



2003

Pressure-lubricated model with industrial-grade two-stage air cleaner added.



## Efficiency, Reliability, Built to Last

Time-tested design and enhancements establish Ingersoll Rand single and two-stage reciprocating compressors as the benchmark for:

### Efficiency and Reliability

With a proven design and stellar track record, the Ingersoll Rand reciprocating compressor family has earned worldwide recognition for reliable, trustworthy performance that saves money and enhances business success through:

- Lower life-cycle costs
- An ability to thrive in punishing applications
- Optimum solutions for greater efficiency
- Configurations that meet varying needs

### Built to Last

Due to the laws of physics, there are certain aspects of reciprocating compressor design, construction and performance that have never changed – like cast-iron durability, copper-finned cooling coils, reliable splash lubrication and easy maintenance. That's where Ingersoll Rand's design and operating experience really pays off in terms of long-term productivity and return on investment. Ask any one of the millions of active Ingersoll Rand reciprocating compressor users around the world.

### Serviceability

Ingersoll Rand designed the reciprocating compressors to last a lifetime – thanks to quick, easy maintenance with renewable components. Easy access to the pump components allows for quick routine maintenance and replacement of parts like the stainless steel valve, individually cast cylinders, piston rings and gaskets, and long-life bearings. This key serviceability aspect extends the life of the compressor and lets you amortize your initial capital cost over a much longer equipment life span for a superior payback on your investment.



## The Ideal Design for Applications Where Air is Taken for Granted

### Innovation

For more than 100 years, Ingersoll Rand has maintained the delicate balance between known performance and new developments by keeping the best features and upgrading others as new technology becomes available. The result is higher efficiency for today's energy-conscious world and enhanced value for the extended life of your investment.

### Customer-driven Solutions

Another residual benefit of compressor longevity is our cumulative experience with how different users prefer, need and operate their compressors. Years of experience in the reciprocating compressor business and servicing a variety of users have taught us what is most important to compressor users. And that means more choices for you to satisfy your specific needs.

Your choices range from the size of the units and the sophistication of the features to popular packaged solutions. There are even gas-powered packages perfect for field service, fleet maintenance, remote pneumatic applications or emergency back-up needs.



Ingersoll Rand single- and two-stage reciprocating air compressors are an ideal choice for applications that demand a reliable air supply for everyday use, but where running an air compressor ranks a distant second to running your business.

- Automotive Shops
- Light Manufacturing
- Construction
- Commercial Applications
- Fabrication
- Pneumatic Equipment
- Processing Lines

# It's All About Choices

**Better choices lead to better solutions** for saving money and improving overall return on investment in your unique application.

That's why Ingersoll Rand single- and two-stage reciprocating compressors offer you more choices of compressor sizes and compressor features to suit your needs. If you define unsurpassed performance by maximum operating pressure, increased air flow and extended duty cycles, count on an Ingersoll Rand reciprocating air compressor to deliver it reliably.

Take advantage of Ingersoll Rand expertise, product selection, service and system solutions to help you identify the optimum compressor size, performance features and package options for your applications. And learn how you can strengthen your business through:

- Lower operating costs
- Increased productivity
- Improved quality
- A better working environment

Two-stage Electric-powered Air Compressors			
Feature	Value Package (5, 7.5, 10 & 15hp)	Value Pro Package (10 & 15hp)	Premium Package (5, 7.5, 10, 15 & 20hp)
100% Cast Iron Pump	✓	✓	✓
ASME Coded Receiver Tank	✓	✓	✓
NEMA 1 & ODP Motor	✓	✓	✓
Magnetic Motor Starter	✓ (Except 2340 packages with single-phase voltage)	✓	✓ (Except 2340 packages with single-phase voltage)
Automatic Start/Stop Control with Pressure Switch	✓	✓	✓ (5 & 7.5hp only)
Oil Sight Glass	✓ (10 & 15hp only)	✓	
Manual Drain	✓		
Electric Drain		✓	✓
Air-Cooled Aftercooler		✓	✓
Low Oil Level Switch			✓
Dual Control with Centrifugal Unloader			✓ (10 & 15hp only)

**Value Package (5, 7.5, 10 & 15hp)** An economical choice in a dependable compressed air source, the Value Package offers the perfect solution for commercial, automotive and light industrial applications with intermittent load demands.

**Value Pro Package (10 & 15hp)** For applications that demand a heavier-duty cycle. Step up to this enhanced version of our base package. It is ideal for light industry applications. The Value Pro Package comes factory-fitted with options shown above for unmatched reliability in most diversified applications.

**Premium Package (5, 7.5, 10, 15 & 20hp)** For applications that are the most demanding or require greater control over compressed air supply. Step up to our top-of-the-line Premium Package. These air compressors come standard with factory-fitted options shown above for unmatched reliability in 100% continuous-duty applications.



### Single-stage Air Compressor

Configured in space-saving stationary and portable models, these durable compressors are a favorite with DIY homeowners and in the construction industry.

Key features include:

- Industry-leading 5,000-8,000 hour design life
- Industrial-quality cast iron construction
- Fully-balanced crankshaft that reduces vibration
- 135 psi max. discharge pressure
- Honda engine-driven wheel barrow compressor



### Two-stage Gas-powered Air Compressors

Ingersoll Rand's two-stage gasoline engine driven air compressors are designed to provide compressed air where electric power is not readily available. They're used in fleet and field service applications, remote pneumatic applications and emergency production lines.

- Available with easy-starting Honda, or Kohler engines
- Fuel-efficient idle control
- Advanced safety features including low oil level shutdown for gas engines



### Electric-Driven Duplex Air Compressors

Ingersoll Rand duplex reciprocating air compressors offer two individual compressor pumps and two motors mounted on a single tank, providing 100% built-in backup or additional air power for those larger capacity jobs. Includes the legendary T30 pump with value added features in a space saving design ideally suited for tight spaces.

- Durable cast iron design for 100% continuous duty application
- Automatic duplexing or alternating of compressors
- Individually cast cylinders, overhung crankshaft and one piece connecting rod for ease of maintenance
- 175 psig maximum operating pressure



## Why Ingersoll Rand Pumps Are Better... Excellence in Design!



**1 Two-stage Design:** Delivers pressures up to 175 psig

**2 Radial Fins for Maximum Cooling:** Even 360° cooling of barrel cylinders eliminates hot spots

**3 One-piece Connecting Rod:** Fewer wearing parts

**4 Low Oil Level Switch:** Provides constant protection

**5 Centrifugal Unloader:** Ensures loadless starts, for maximum starter protection

**6 Integral Fan Blade/Finned Copper Intercooler:** Runs cooler, even in the most demanding conditions

**7 Overhung Crankshaft:** Precision balanced to run smoothly and quietly; simplifies maintenance and wear-sleeve replacement

**8 Splash Lubrication:** Simple and reliable.

**9 100% Cast Iron:** Designed for a lifetime

# Selection Guide for Electric-drive Stationary Air Compressors

## 1. Select Your Compressor

Stationary Compressors	
Applications	Recommended Package
Intermittent Duty	Two-stage Value
Medium Duty	Two-stage Value Pro
100% Continuous Duty	Two-stage Premium
DIY	Single-stage

Portable Compressors	
Applications	Recommended Package
Remote/Fleet/ Field Service	Two-stage Gas-driven
DIY/Construction	Single-stage



## 2. Choose Your Air Quality

Ingersoll Rand compressed air treatment equipment is used to remove contaminants present in a compressed air system.

### Shop Quality Air

General system protection removes bulk liquid and solid contaminants:

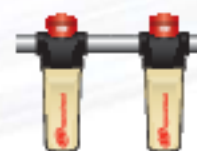

G Filter H Filter

- Light manufacturing
- Light auto service shop
- Pneumatic tools
- Dry cleaning

### Dry, Clean Air

Complete system protection removes liquid and solid contaminants:



G Filter Refrigerated Dryer H Filter

- Medium-to-heavy manufacturing
- Large auto service shop
- Auto body shop
- Laundry
- Printing
- Instrumentation

### Critical Quality Air

Applications that require virtually no water vapor or contaminants:

- Advanced pneumatics and instrumentation
- Spray application booths
- Piping exposed to freezing temperatures



G Filter H Filter D Filter

Desiccant Dryer

G - General Purpose H - High Efficiency D - Dust Protection

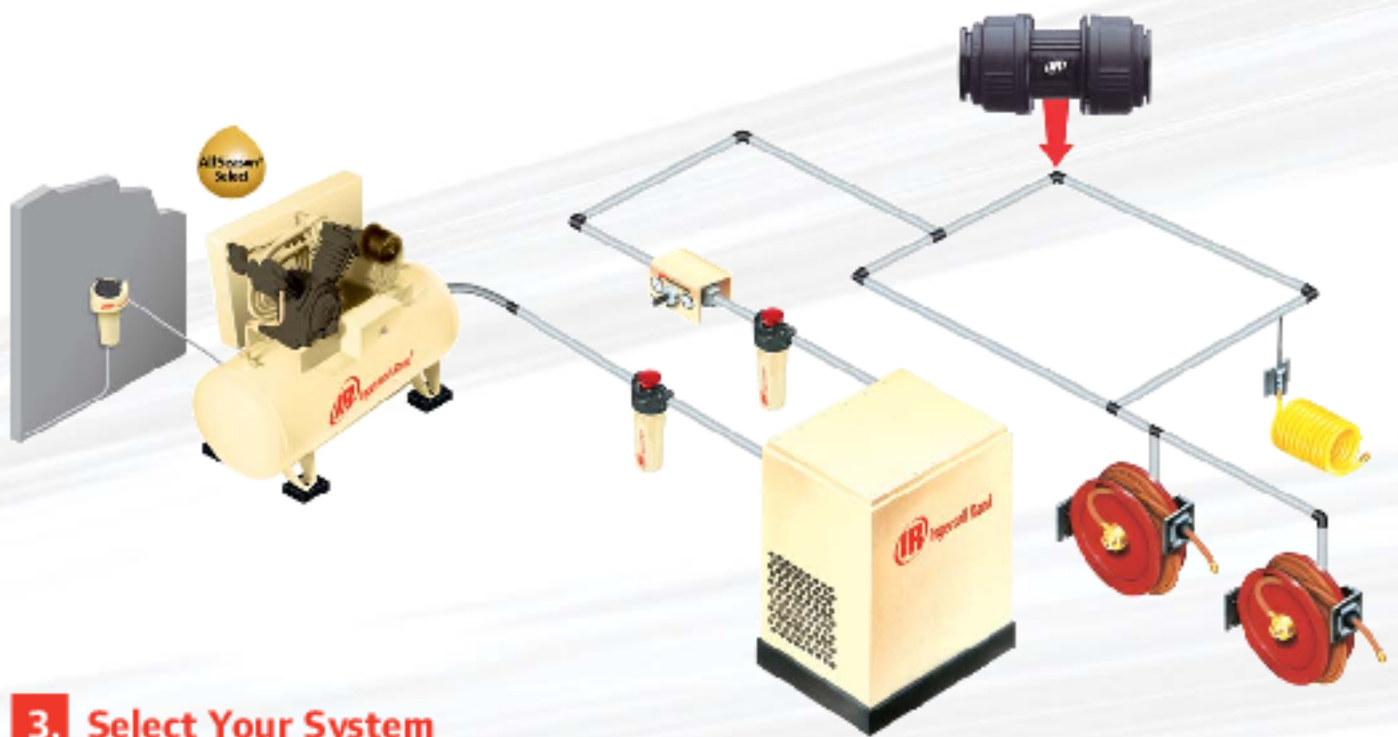

### 3. Select Your System Controls and Accessories

Ingersoll Rand accessories are available for all power sources.

#### IntelliFlow Pneumatic Flow Controller



- Energy savings
- Control pressure off 1 psig (.07 bar g)
- Single point control system
- Reduce leak losses
- Increase system productivity
- Protect all downstream equipment

#### EZ-line SimpiAir Compressed Air Piping

- High-quality anodized aluminum pipe
- Non-corrosive piping
- Reduced pressure loss
- Higher flow rates than other piping
- Easy and fast installation



#### EDV Electronic Drain Valve

- Automatically removes moisture from tanks, compressors, filters, drip legs



#### Filters, Regulators and Lubricators (FRLs)

FRLs provide point-of-use air conditioning to enhance tool longevity and process quality. Filters remove rust, scale and condensation that increase wear on tools, regulators and provide constant pressure with varying upstream pressure. Lubricators provide lubricating oil to tools, cylinders, valves and other equipment.



#### Oil Water Separators

- Removes oil from drain condensate
- Allows for clean water discharge



# Global Reach, Local Touch

No matter what the industry or location, Ingersoll Rand is committed to serving you 24 hours a day, seven days a week. Our worldwide network of distributors, engineers and certified, factory-trained technicians, are a phone call away — ready to support you with innovative and cost-effective service solutions that will keep you running at peak performance.



## All Season Select® Start-up Kits



Ingersoll Rand offers All Season Select® start-up kits to provide improved protection. Each kit contains all the parts needed to start up and maintain your compressor for the first year. Kits provide everything you need for 2,000 hours of service between changes under normal operating conditions, along with the added protection of a two-year extended warranty.

All start-up kits include:

- All Season Select® lubricant, our synthetic, all-temperature blend designed to increase efficiency, reduce wear and prevent carbon build-up
- Replacement air filter elements

## Specifications - Duplex Packages

### Two-stage Electric-powered Value Packages

Model	hp	Tank Size/ Configuration	Stationary or Portable	Capacity (cfm) @ 90 psig	Max Pressure (psig)	Dimensions (L x W x H in)	Net Weight (lbs)	Tank Outlet (in)	Start up Kit
2-2475E5-V	5	120-Gal. Horizontal	5	34.2	175	82 x 33 x 48	1,250	0.5	32282881
2-2475E7.5-V	7.5	120-Gal. Horizontal	5	48.2	175	82 x 33 x 48	1,275	0.5	32282881
2-2546E10-V	10	120-Gal. Horizontal	5	70.4	175	87 x 33 x 52	1,530	0.5	32282899

Available voltages: 200/3/60, 230/3/60, 460/3/60 and 575/3/60

### Two-stage Electric-powered Premium Packages

Model	hp	Tank Size/ Configuration	Stationary or Portable	Capacity (cfm) @ 175 psig	Max Pressure (psig)	Dimensions (L x W x H in)	Net Weight (lbs)	Tank Outlet (in)	Start up Kit
2-2475E5-P	5	120-Gal. Horizontal	5	34.2	175	84 x 35 x 48	1,265	0.5	32282881
2-2475E7.5-P	7.5	120-Gal. Horizontal	5	48.2	175	84 x 35 x 48	1,315	0.5	32282881
2-2546E10-P	10	120-Gal. Horizontal	5	70.4	175	88 x 35 x 52	1,545	0.5	32282899

Available voltages: 200/3/60, 230/3/60, 460/3/60 and 575/3/60

# Specifications - Simplex Packages

## Two-stage Electric-powered – Value Package

Model	hp	Tank Size/ Configuration	Stationary or Portable	Capacity (cfm) @ 175 psig	Max Pressure (psig)	Dimensions (L x W x H in)	Net Weight (lbs)	Tank Outlet (in)	Startup Kit
2340LS-V	5.0	60-Gal. Vertical	S	14.0	175	48 x 40 x 76	435	0.50	32305880
2340NS-V	5.0	80-Gal. Vertical	S	14.0	175	48 x 40 x 76	505	0.50	32305880
2475NS-V	5.0	80-Gal. Vertical	S	16.8	175	48 x 40 x 76	505	0.75	32305880
2475N7.5-V	7.5	80-Gal. Vertical	S	24.0	175	48 x 40 x 76	611	0.75	32305880
2545E10-V	10.0	120-Gal. Horizontal	S	35.0	175	83 x 36 x 65	920	0.75	32305898
2545K10-V	10.0	120-Gal. Vertical	S	35.0	175	51 x 46 x 83	1,104	1.00	32305898
7100E15-V	15.0	120-Gal. Horizontal	S	50.0	175	83 x 36 x 65	1,239	0.75	32305898

Available voltages: 230/1/60 (5-7.5 hp only), 200/3/60, 230/3/60, 460/3/60 and 575/3/60 voltages

Packages include magnetic starter (except 2340 models with single-phase voltage), manual drain, automatic start/stop control with pressure switch

## Two-stage Electric-powered – Value Pro Package

Model	hp	Tank Size/ Configuration	Stationary or Portable	Capacity (cfm) @ 175 psig	Max Pressure (psig)	Dimensions (L x W x H in)	Net Weight (lbs)	Tank Outlet (in)	Startup Kit
2545E10-VP	10.0	120-Gal. Horizontal	S	35.0	175	83 x 36 x 65	1,104	0.75	32305898
2549K10-VP	10.0	120-Gal. Vertical	S	35.0	175	51 x 46 x 83	1,104	1.00	32305898
7100E15-VP	15.0	120-Gal. Horizontal	S	50.0	175	83 x 36 x 65	1,297	0.75	32305898

Available voltages: 200/3/60, 230/3/60, 460/3/60 and 575/3/60 voltages

Packages include magnetic starter, electric drain, Automatic start/stop control with pressure switch, air-cooled aftercooler

## Two-stage Electric-powered – Premium Package

Model	hp	Tank Size/ Configuration	Stationary or Portable	Capacity (cfm) @ 175 psig	Max Pressure (psig)	Dimensions (L x W x H in)	Net Weight (lbs)	Tank Outlet (in)	Startup Kit
2475NS-P	5.0	80-Gal. Vertical	S	16.8	175	48 x 40 x 76	597	0.75	32305880
2475N7.5-P	7.5	80-Gal. Vertical	S	24.0	175	48 x 40 x 76	611	0.75	32305880
2545E10-P	10.0	120-Gal. Horizontal	S	35.0	175	83 x 36 x 65	1,104	0.75	32305898
2549K10-P	10.0	120-Gal. Vertical	S	35.0	175	51 x 46 x 83	1,104	1.00	32305898
7100E15-P	15.0	120-Gal. Horizontal	S	50.0	175	83 x 36 x 65	1,297	0.75	32305898

Available voltages: 230/1/60 (5-7.5 hp only), 200/3/60, 230/3/60, 460/3/60 and 575/3/60 voltages

Packages include magnetic starter, electric drain, automatic start/stop control with pressure switch (5 hp & 7.5hp), dual control with centrifugal unloader (10hp & 15hp), air-cooled aftercooler, low oil level switch

## Single-stage Electric-powered

Model	hp	Tank Size/ Configuration	Stationary or Portable	Capacity (cfm) @ 90 psig	Max Pressure (psig)	Dimensions (L x W x H in)	Net Weight (lbs)	Tank Outlet (in)	Startup Kit
P11U-A9	2.0	4-Gal. Twin	P	4.30	135	19 x 19 x 19	77	0.25	-
P1.9U-A9	2.0	20-Gal. Vertical	P	5.20	135	22 x 23 x 43	200	0.25	-
S53J2-WB	2.0	8-Gal. Twin	P	5.70	135	43 x 18 x 25	175	0.25	97338099
S53J3-WB	3.0	8-Gal. Twin	P	11.3	135	43 x 18 x 25	175	0.25	97338099
S53L3	3.0	60-Gal. Vertical	S	11.3	135	20 x 23 x 66	300	0.50	97338099
S55L5	5.0	60-Gal. Vertical	S	18.1	135	20 x 30 x 71	310	0.50	20100251

Available voltages: 120/1/60 (P11U-A9), 115/1/60 (P1.9U-A9), and 230/1/60 (S53, S55) voltages

## Two-stage Gas-powered

Model	hp	Engine	Tank Size/ Configuration	Stationary or Portable	Capacity (cfm) @ 175 psig	Max Pressure (psig)	Dimensions (L x W x H in)	Net Weight (lbs)	Tank Outlet (in)	Startup Kit
2475F13GH	13	Honda	30-Gal. Horizontal	P	25.0	175	51 x 33 x 44	469	0.50	32312936
2475X13GH	13	Honda	Baseplate Mounted	P	25.0	175	33 x 36 x 36	440	0.50	32312936
2475F12.5G	13	KoHer	30-Gal. Horizontal	P	24.0	175	51 x 33 x 44	469	0.50	32305872
2475X12.5G	13	KoHer	Baseplate Mounted	P	24.0	175	33 x 36 x 36	440	0.50	32305872

## Single-stage Gas-powered

Model	hp	Engine	Tank Size/ Configuration	Stationary or Portable	Capacity (cfm) @ 90 psig	Max Pressure (psig)	Dimensions (L x W x H in)	Net Weight (lbs)	Tank Outlet (in)	Startup Kit
S53J5.5QH-WB	5.5	Honda	8-Gal. Twin	P	11.8	135	43 x 18 x 26	175	0.25	97339501



Ingersoll Rand Industrial Technologies provides products, services and solutions that enhance our customers' energy efficiency, productivity and operations. Our diverse and innovative products range from complete compressed air systems, tools and pumps to material and fluid handling systems and environmentally friendly microturbines. We also enhance productivity through solutions created by Club Car®, the global leader in golf and utility vehicles for businesses and individuals.

[www.ingersollrandproducts.com](http://www.ingersollrandproducts.com)

Distributed by:



Ingersoll Rand compressors are not designed, intended or approved for breathing air applications. Ingersoll Rand does not approve special equipment for breathing air applications and as such has no responsibility or liability for compressors used for breathing air service.

Nothing contained on these pages is intended to extend any warranty or representation, expressed or implied, regarding the product described herein. Any such warranties or other terms and conditions of sale of products shall be in accordance with Ingersoll Rand's standard terms and conditions of sale for such products, which are available upon request.

Product improvement is a continuing goal of Ingersoll Rand. Designs and specifications are subject to change without notice or obligation.